

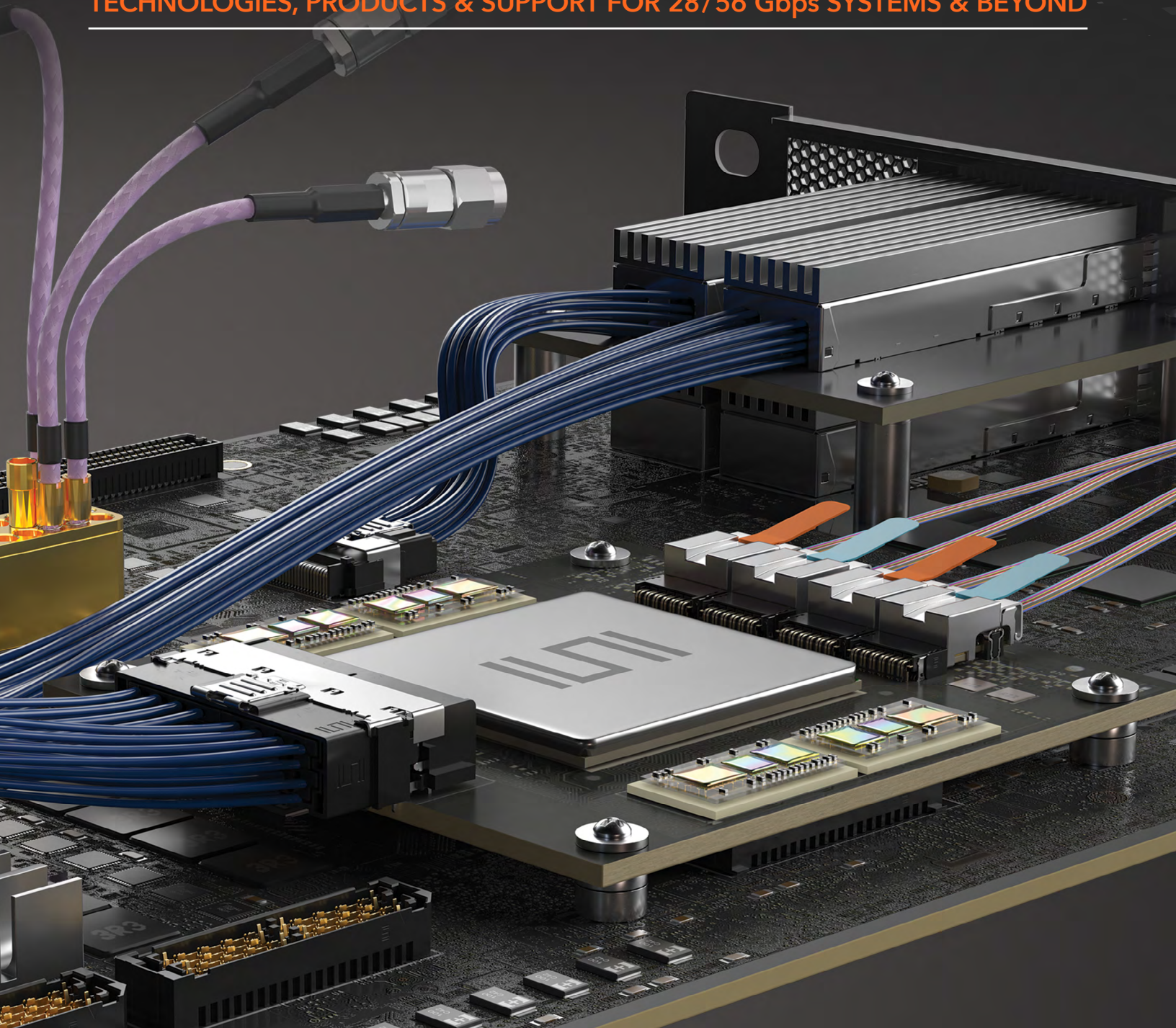

SILICON-TO-SILICON APPLICATION SOLUTIONS GUIDE

TECHNOLOGIES, PRODUCTS & SUPPORT FOR 28/56 Gbps SYSTEMS & BEYOND





NEXT GENERATION SOLUTIONS FOR 28/56 Gbps SYSTEMS & BEYOND

As data rate requirements approach and surpass 56 Gbps, developers are challenged with balancing increasing throughput, scalability and density demands with concerns such as power consumption, signal integrity, cost and time-to-market. Samtec helps address these challenges with industry-leading expertise in high-performance interconnect design, system optimization, and innovative strategies and technologies for the demands of next generation data transmission.

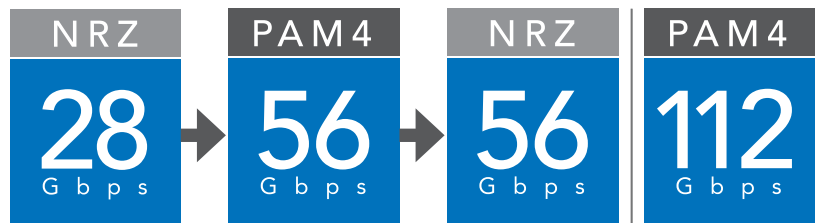

High-Speed Interconnect Expertise

Innovative products and industry-leading technologies are engineered to support the demands of next generation systems.

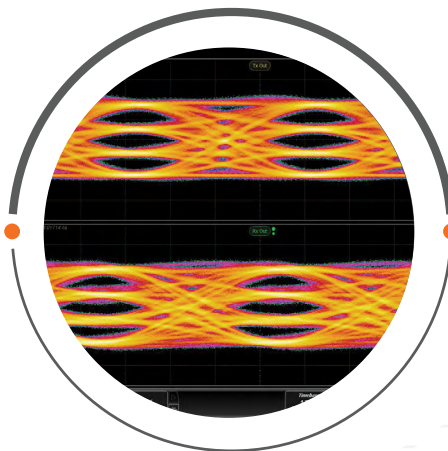

High-Performance SI Characterization Testing & Validation

High-level design assistance and engineering support for the entire high-speed signal path - from bare die, to IC package, to PCB, to connectors and cables, and back again.



Online Design Tools and Resources

Easy-to-navigate tools and a vast online technical library help to quickly determine the right solution for every application.

TABLE OF CONTENTS

HIGH-SPEED BACKPLANE

6-7



HIGH-SPEED MEZZANINE

8-9

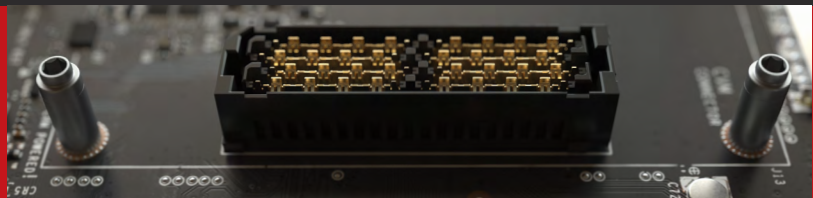

TWINAX FLYOVER™ SYSTEMS

10-11

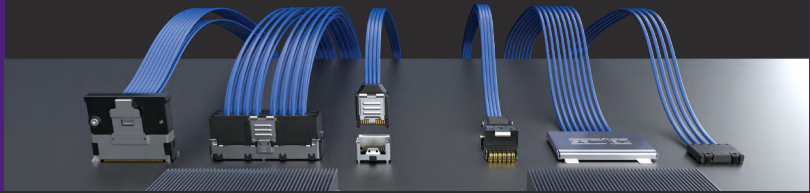

HIGH-PERFORMANCE OPTICS

12-13

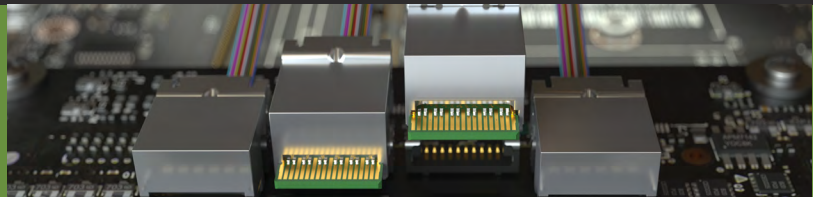

MICROELECTRONICS

14-15

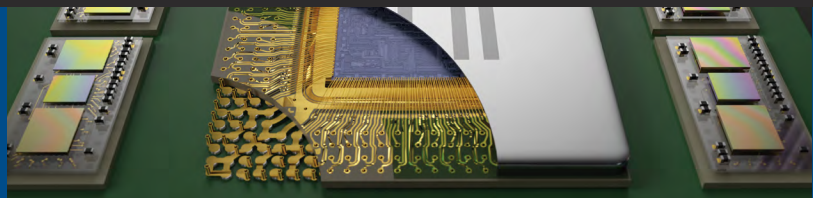

PRECISION RF / TEST

16-17

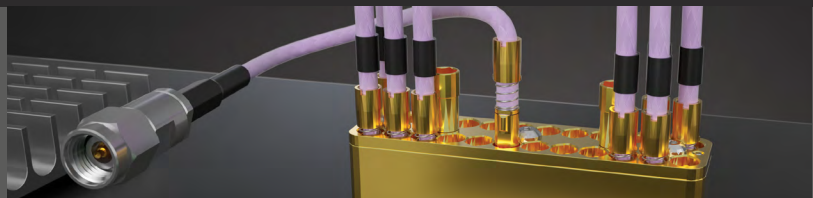

Samtec Technology Centers: Full System Support	18
Samtec Development Board Reference Guide	19
Samtec SI Characterization Kit Reference Guide	20-21

FULL SYSTEM OPTIMIZATION

High-Speed Backplane

High-density cables and connectors enable 56+ Gbps performance.

6-7

High-Speed Mezzanine

Ultra-high-speed strips, edge card sockets and ultra-high-density arrays.

8-9

Twinax Flyover™ Systems

Improve signal integrity and simplify layouts by “flying” critical data over the board.

10-11

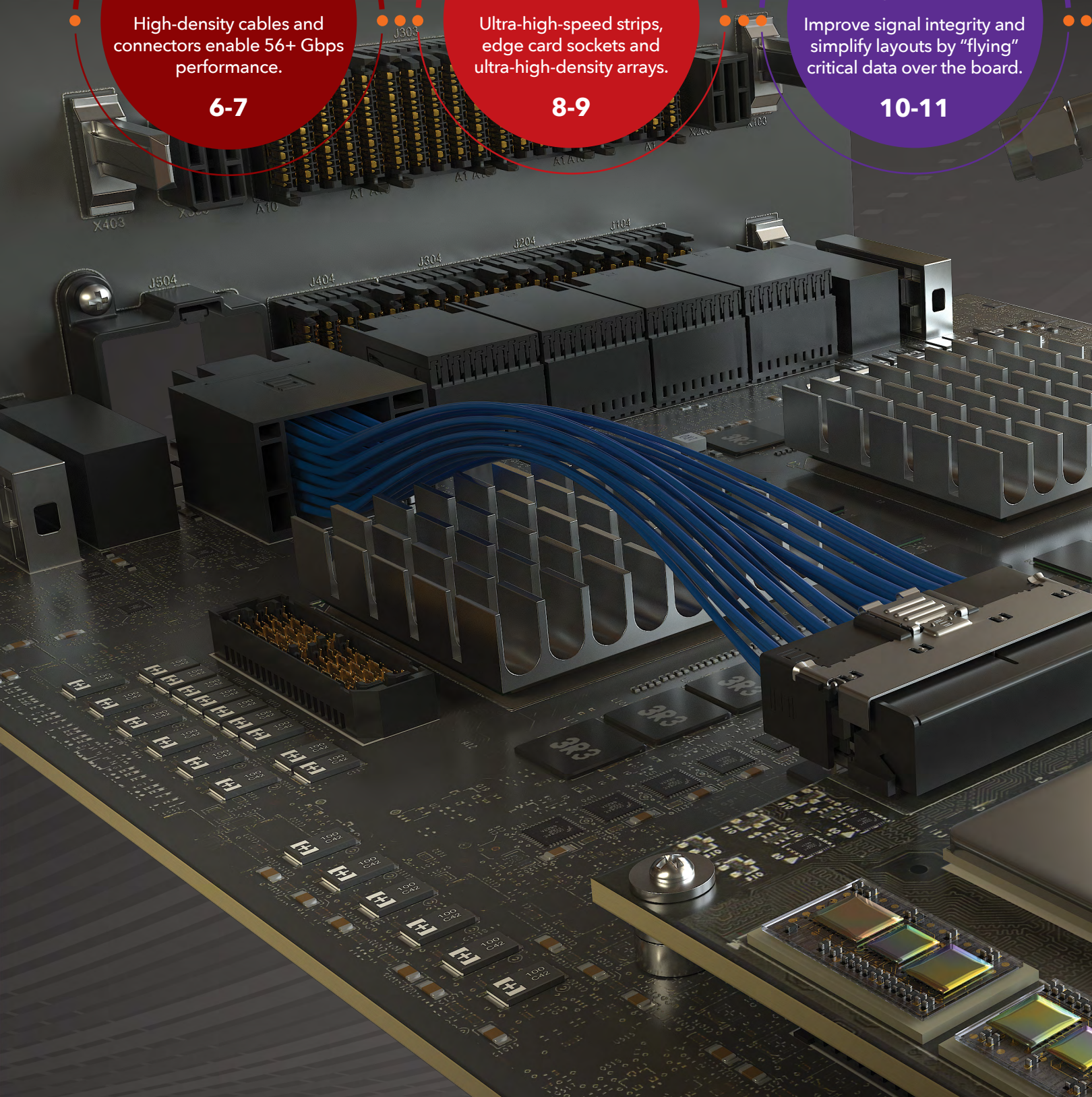

FROM SILICON-TO-SILICON™

High-Performance Optics

Scalable, manufacturable, cost-efficient optical solutions for 28+ Gbps applications.

12-13

Advanced Microelectronics

Glass Core Technology (GCT), IC packaging & assembly, next gen 2.5D / 3D solutions.

14-15

Precision RF / Test Systems

High-density systems enable optimized performance to 50+ GHz.

16-17

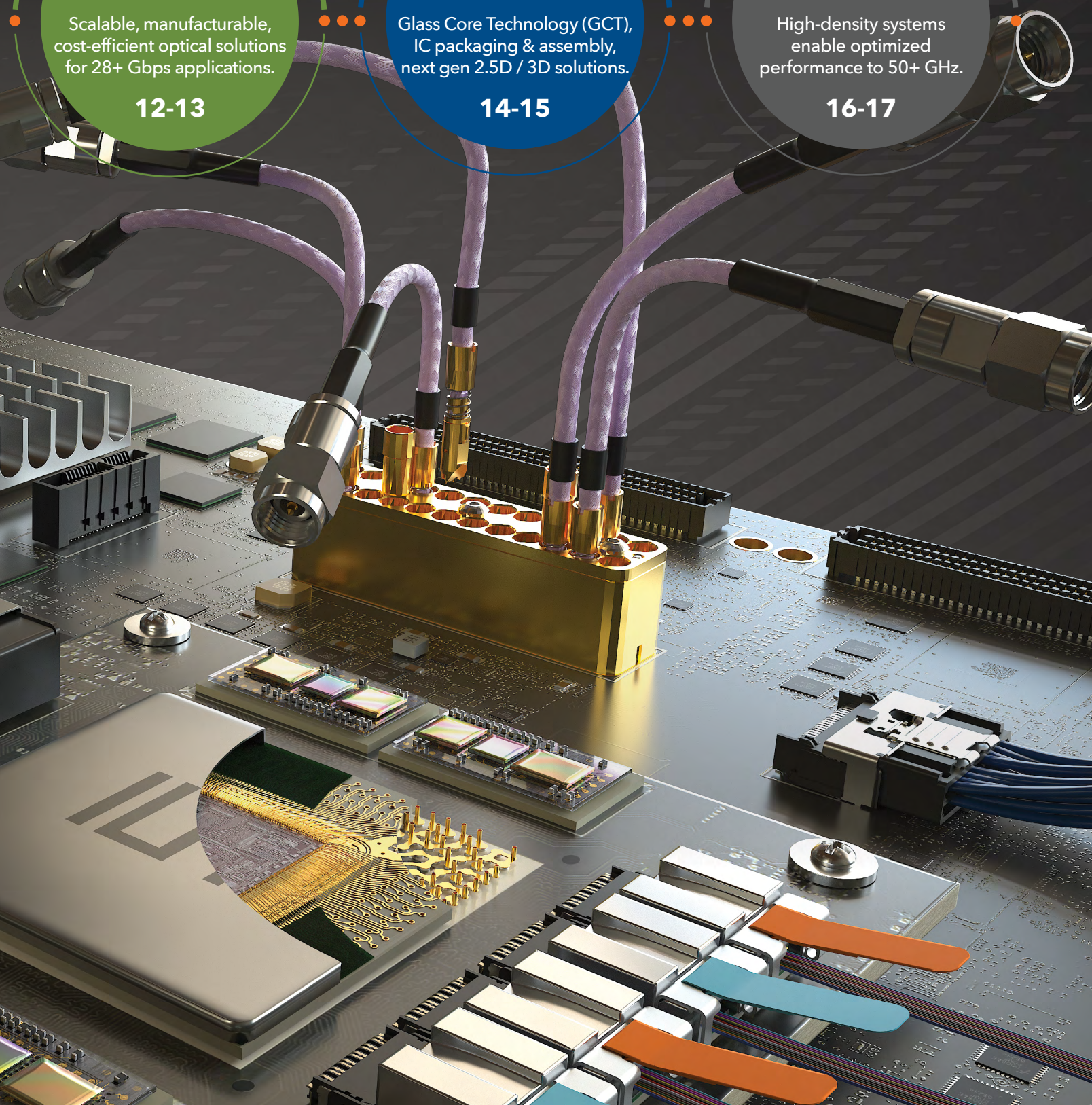

HIGH-SPEED BACKPLANE

ExaMAX® traditional high-speed backplane interconnects enable 56 Gbps electrical performance on 2.00 mm pitch. The system meets industry specifications including PCI Express®, Intel OPI and UPI, SAS, SATA, Fibre Channel, InfiniBand™ and Ethernet. Additionally, the direct-mate orthogonal system eliminates the need for a backplane/midplane and shortens the signal path for improved signal integrity. The technology roadmap for ExaMAX® includes coplanar and backplane cable assemblies, which are currently in development.

ExaMAX®

ExaMAX® Traditional
(2.00 mm Pitch)



ExaMAX® Direct-Mate Orthogonal
(2.00 mm Pitch)



ExaMAX® High-Speed Backplane
Cable Assemblies

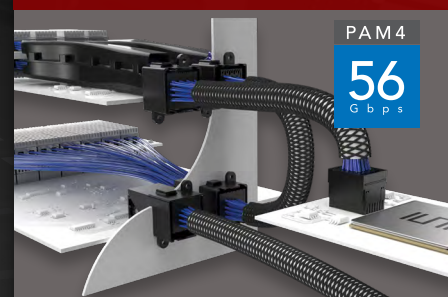

DEVELOPMENT PLATFORMS

Xilinx® Virtex® UltraScale™ FPGA VCU110 Development Kit

- The combination of the VCU110 Development Board and the ExaMAX® Loopback Card provides a platform for demonstrating 28 Gbps performance from an FPGA over Samtec's ExaMAX® backplane connector system
- Eight 28 Gbps GTY MGTs are routed from the FPGA through the ExaMAX® mated connector pair, back to the FPGA
- The kit demonstrates optimized SI performance via Samtec's Final Inch® BOR PCB trace routing for the EBTM Series connector
- ExaMAX® equipped channels meet the IEEE 802.3bj mandated loss performance of 25 db
- Visit samtec.com/standards/fpgavcu110 for additional details

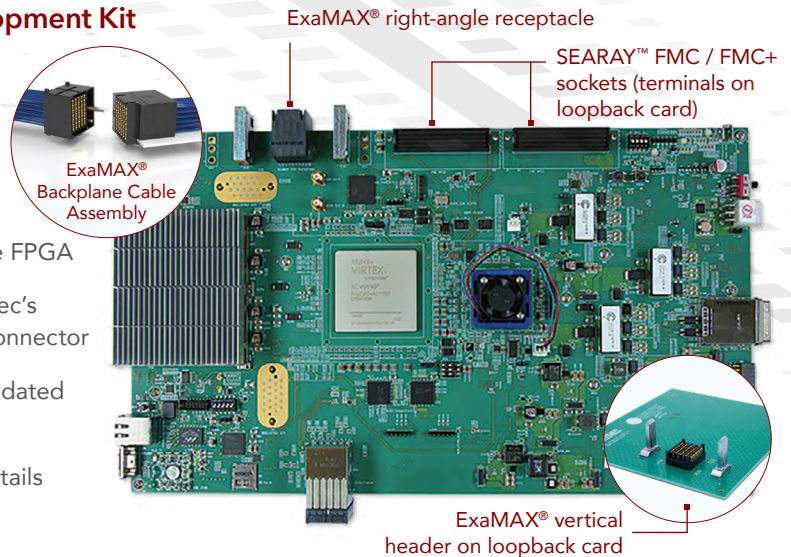

56 Gbps & BEYOND: ExaMAX® HIGH-SPEED BACKPLANE CONNECTORS

ExaMAX® high-speed backplane interconnects deliver 56 Gbps electrical performance, with a contact system that achieves two reliable points of contact at all times and minimizes residual stubs for improved signal integrity performance. The system also offers low mating force and excellent contact normal force. Signal wafers incorporate a one-piece, embossed ground structure which improves crosstalk performance. For additional specifications, please visit samtec.com/examax.

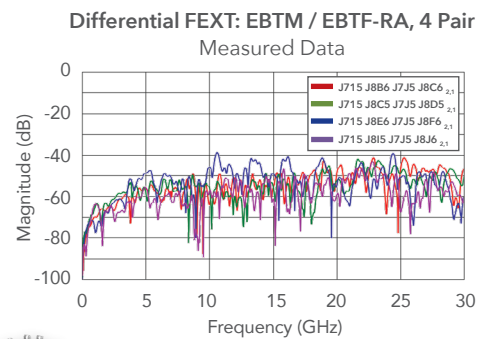
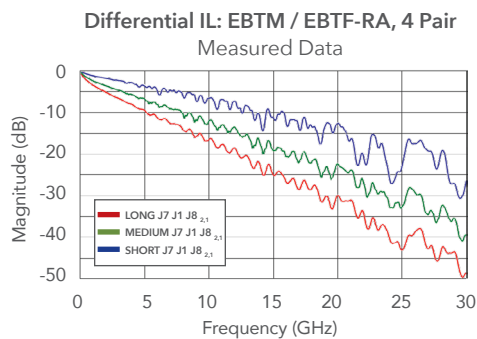
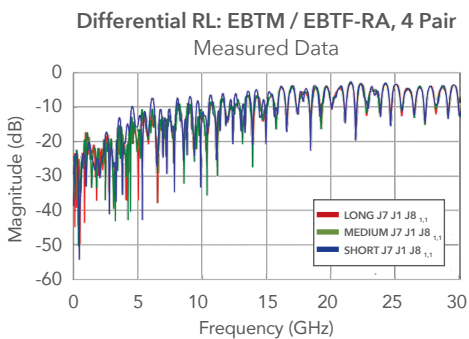

ExaMAX® Signal Integrity Characterization Kit

The ExaMAX® SI Characterization Kit provides system designers and signal integrity engineers an easy-to-use solution for testing ExaMAX® high-speed backplane connectors.

The kit delivers a high-quality system with a robust mechanical design. The modular approach of the kit enables support of multiple configurations for customization to specific applications. For additional information or to order your kit, please contact kitsandboards@samtec.com.

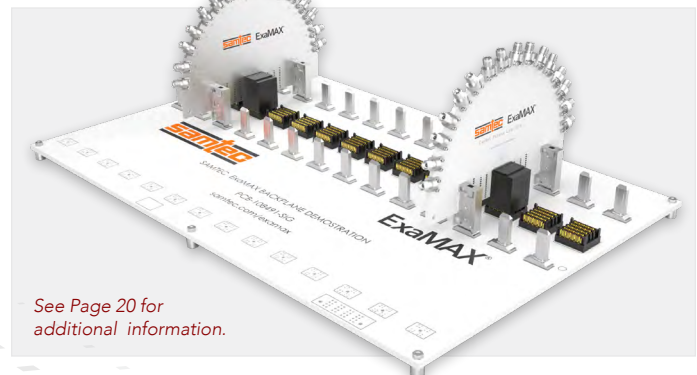

See Page 20 for additional information.

ExaMAX® Characterization Kit breaks out into 8 differential pairs and simulates multiple backplane trace lengths.

HIGH-SPEED MEZZANINE

NovaRay™ 56 Gbps NRZ arrays (with a roadmap to 112 Gbps PAM4) and AcceleRate® HD ultra-high-density strips are two of Samtec's next generation high-performance connector systems. With attributes including low crosstalk, tight impedance control and industry-leading data rates and density, these systems are optimized for the demands of 56 Gbps systems and beyond.

Samtec's SEARAY™ family of high-speed, high-density open-pin-field arrays allow for maximum grounding and routing flexibility and include a choice of pitches and a low-profile design. Samtec FMC connectors are Application Specific Product (ASP) versions of SEARAY™ which are engineered to enable accelerated application development.

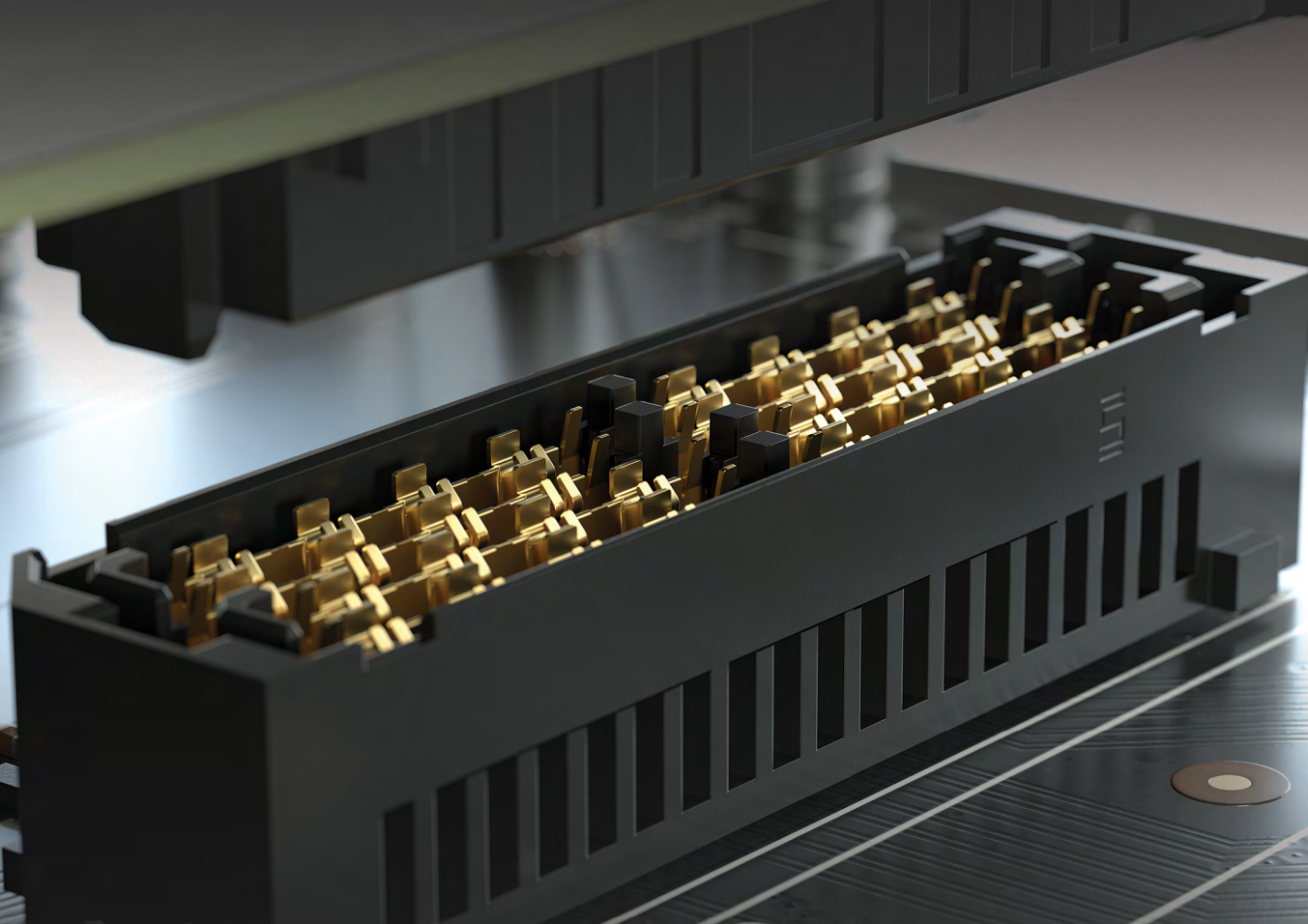

NOVARAY™

ACCELERATE® HD

SEARAY™

Extreme Density Arrays & Cables

Ultra-High-Density Multi-Row Strips
on 0.635 mm Pitch

Open-Pin-Field Arrays,
VITA 57.1 FMC & VITA 57.4 FMC+



NRZ
56
Gbps

PAM4
112
Gbps

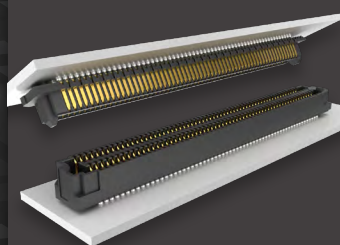

PAM4
56
Gbps

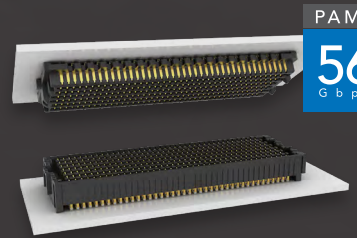

PAM4
56
Gbps

DEVELOPMENT PLATFORMS

Microsemi® PolarFire™ Evaluation Kit

- Ideal for high-speed transceiver evaluation, 10 Gb Ethernet, IEEE1588, JESD204B, SyncE, SATA and more
- Connections include a High Pin Count (HPC) FPGA Mezzanine Card (FMC), numerous SMAs, PCIe®, Dual Gigabit Ethernet RJ45, SFP+ and USB
- Mating connectors for the mezzanine card include ASP-134488-01 for 10 mm stack and ASP-134602-01 for 8.50 mm stack
- Visit samtec.com/fmc for additional details

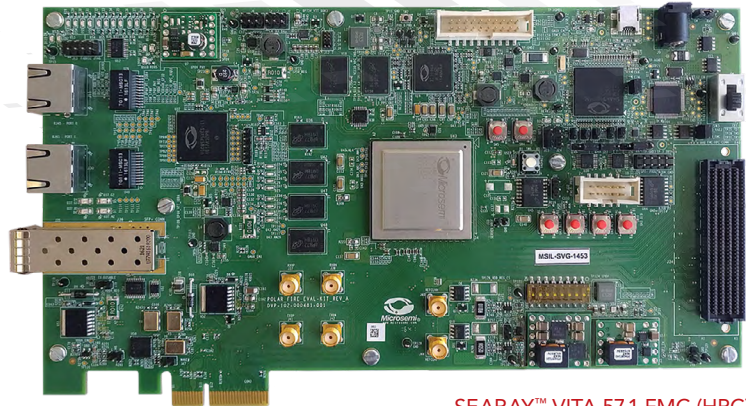

SEARAY™ VITA 57.1 FMC (HPC)
400 I/O female connectors

FMC / FMC+ Development Kits & Boards

- Samtec offers a variety of development kits and boards featuring SEARAY™ VITA 57.1 FMC and VITA 57.4 FMC+ connectors
- Designed to help simplify design and reduce time to market
- Visit samtec.com/kits for details and additional development kits available from Samtec

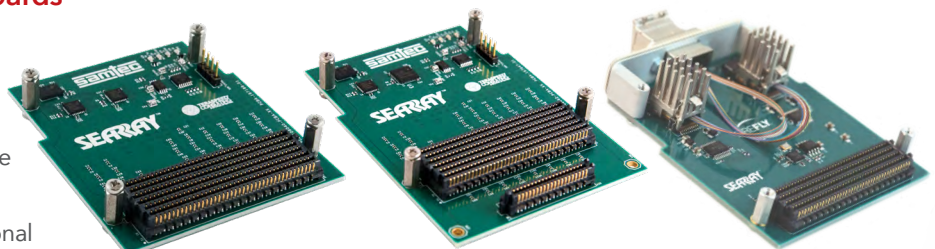

FMC+ HSPC Loopback Card

FMC+ HSPC/HSPCe Loopback Card

14 Gbps FireFly™ FMC Development Kit

56 Gbps & BEYOND: NovaRay™ HIGH-SPEED MEZZANINE CONNECTORS

The NovaRay™ system is 56 Gbps NRZ capable with 112 Gbps PAM4 per channel. A proprietary pin-to-ground configuration enables very low crosstalk to 40 GHz+ and very tight impedance control. The design also enables an industry-leading aggregate data rate average of 1.33 Gbps/sq inch with minimal variance in data rate as stack heights increase. Contact sig@samtec.com for details.

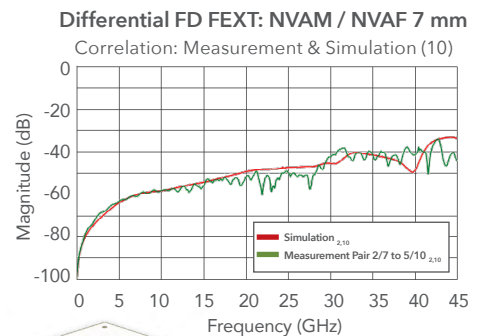
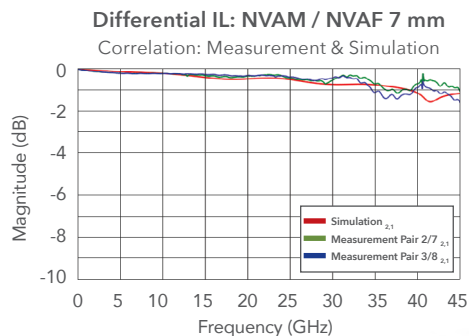
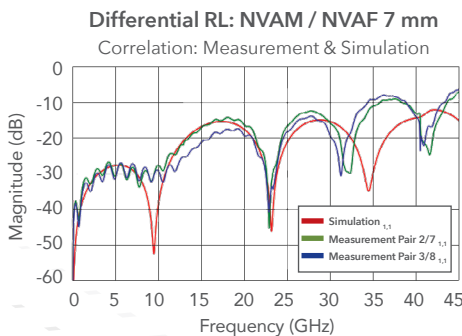

NovaRay™ SI Characterization Kit

The NovaRay® Kit features a 4 row, 2 bank NVAM Series board which can also be used as a flyover evaluator for the NVAM-C Series cable assembly. The kit supports multiple stack heights and RF connector options. For additional information contact kitsandboards@samtec.com.

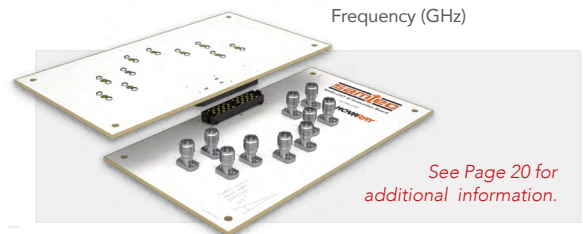

See Page 20 for additional information.

NovaRay™ kit includes boards for headers and sockets.

* PCI-SIG®, PCI Express® and the PCIe® design marks are registered trademarks and/or service marks of PCI-SIG.

TWINAX FLYOVER™ SYSTEMS

As bandwidth requirements rapidly increase, routing signals through lossy PCBs, vias and other components has become one of the most complex challenges designers face. Samtec's Flyover™ architecture breaks the constraints of traditional signaling substrate and hardware offerings, resulting in a cost-effective, high-performance answer to the challenges of 56 Gbps bandwidths and beyond.

By "flying" critical high-speed signals over lossy PCB materials and directly to the panel, signal integrity and architectural flexibility are improved, while layout complexity is decreased. Samtec's Flyover™ systems include ultra-low skew twinax cable and high-performance optical assemblies. Contact hdr@samtec.com to discuss your application.

NOVARAY™

ACCELERATE®

FLYOVER™

Extreme Data Rate & Density
Flyover™ System



Ultra-Slim, Ultra-Dense
2-Row Flyover™ System

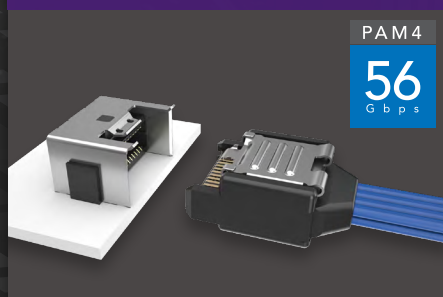

QSFP28 Double-Density
and QSFP28 Flyover™ Systems



DEVELOPMENT PLATFORMS

Xilinx Virtex® UltraScale™ FPGA VCU118 Evaluation Kit

- Optimized for quickly prototyping applications using Virtex® UltraScale™+ FPGAs
- Kit includes Development Board and FMC+ Active Loopback Card with Samtec's high-performance QSFP28 and FireFly™ Twinax Micro Flyover Systems™ and VITA 57.1 FMC and 57.4 FMC+ connectors
- Standard Loopback Card contains FireFly™ Twinax Micro Flyover System™ (optional x4 28 Gbps FireFly™ optical system with pin fin heatsink also available)
- Visit samtec.com/standards/fpgavcu118 for additional details and ordering information

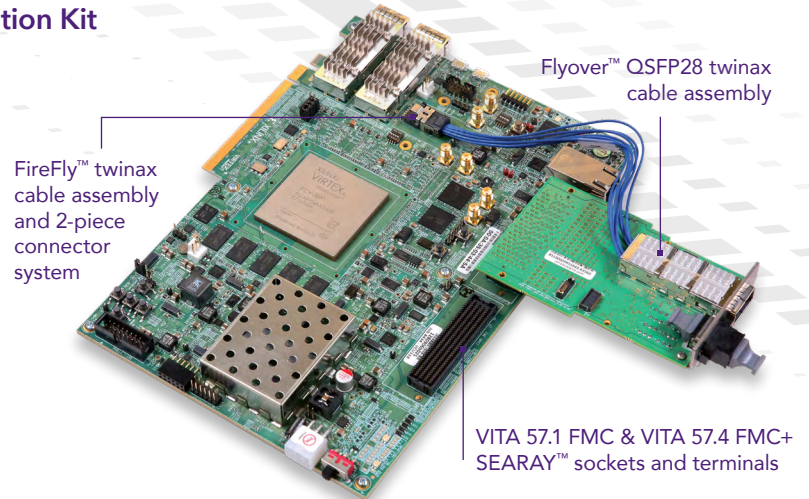

56 Gbps & BEYOND: FLYOVER™ QSFP28 & FLYOVER™ QSFP28-DOUBLE DENSITY

Twinax Flyover™ QSFP28 systems leverage the performance advantages of Samtec's ultra-low skew twinax cable, which enables significantly better signal integrity in comparison to PCB traces. The low loss of the twinax cable also means that the SERDES can be located much further from the front panel opening options for the mechanical architecture of the switch.

The system is available in a 4-channel configuration (FQSFP Series) with an aggregate bandwidth of 100 Gbps NRZ (200 Gbps PAM4), and an 8-channel configuration (FQSFP-DD Series) with an aggregate bandwidth of 200 Gbps NRZ (400 Gbps PAM4).

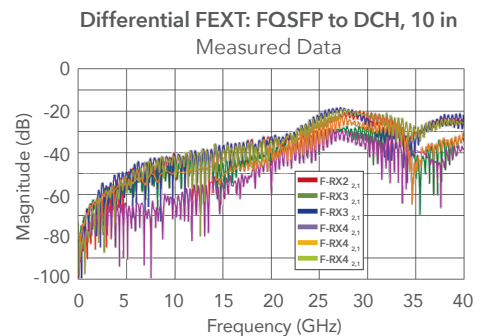
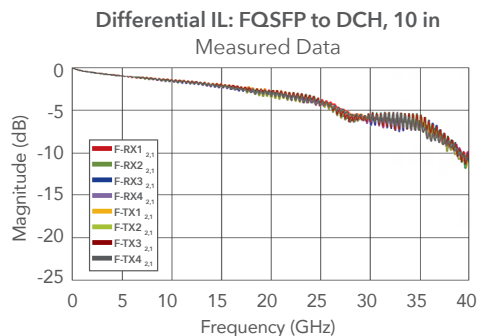
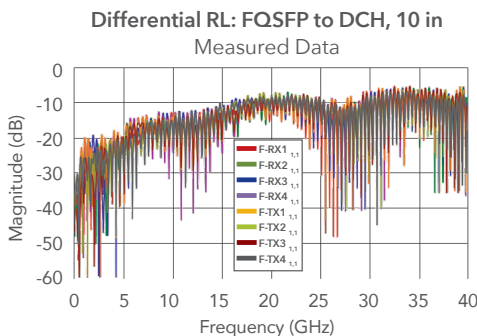

Flyover™ QSFP28 SI Characterization Kit

The Flyover™ QSFP28 SI Characterization Kit provides system designers and signal integrity engineers an easy-to-use solution for testing FQSFP Series Twinax Flyover™ Cable Assemblies.

The kit delivers a high-quality system with a robust mechanical design. The modular approach of the kit enables support of multiple FQSFP End 2 cable assembly and SI characterization card options. For additional information, visit samtec.com/flyover.

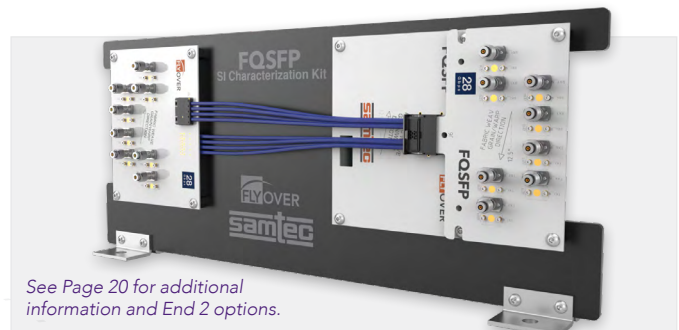

Flyover™ QSFP28 Kit shown with FQSFP twinax cable assembly on End 1 and DCH Series high-speed press-fit connectors on End 2.

HIGH-PERFORMANCE OPTICS

Samtec's in-house Optical Group provides design, development and application support for high-performance micro optics, PCIe®-Over-Fiber and Silicon Photonics solutions that are scalable, manufacturable, and cost-efficient for 56+ Gbps applications. FireFly™ Optical Micro Flyover System™ is one such solution, with benefits including an ultra micro footprint for industry-leading density, enhanced signal integrity, and architectural flexibility. Contact firefly@samtec.com to discuss your application.



FIREFLY™

High-Performance
Micro Optical Engine Technology

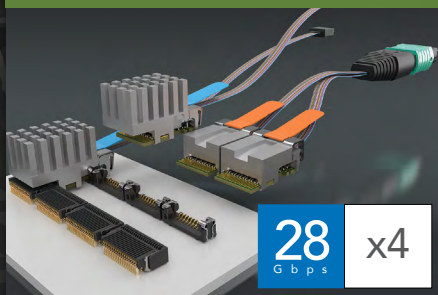

PCIe®-Over-Fiber Optical
Assembly and Adaptor Card

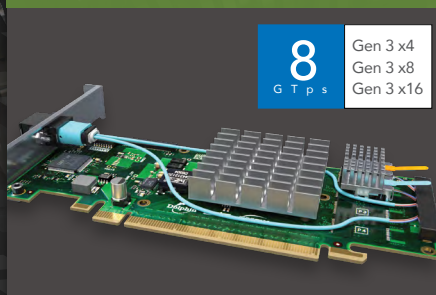

Solutions for Standard
and Custom Applications

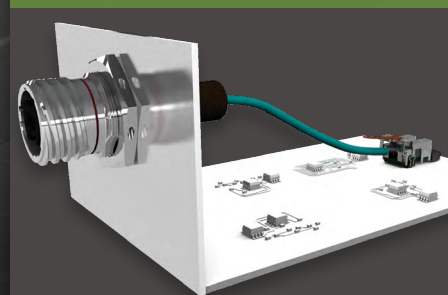

DEVELOPMENT PLATFORMS

FireFly™ 14 Gbps FMC & 28 Gbps FMC+ Development Kits

- FireFly™ optical engines provide adjustable power levels to support cable lengths up to 100 meters
- Kits support Data Center, HPC and FPGA-to-FPGA protocols including Ethernet, InfiniBand™, Fibre Channel and Aurora
- **14 Gbps FireFly™ FMC Development Kit:**
 - Provides up to 140 Gbps full-duplex bandwidth over 10 channels from an FPGA to an industry-standard multi-mode fiber optic cable
 - As a VITA 57.1 FMC module, the 14 Gbps kit can run actual system data or BERT testing on all channels at the same time, making evaluation with a specific FPGA much easier
- **28 Gbps FireFly™ FMC+ Development Kit:**
 - Provides up to 448 Gbps full-duplex bandwidth over 16 channels from an FPGA to an industry-standard multi-mode fiber optic cable
 - As a VITA 57.4 FMC+ module, the kit can run actual system data or BERT testing on all channels at the same time, making evaluation with a specific FPGA much easier
- For additional details contact firefly@samtec.com

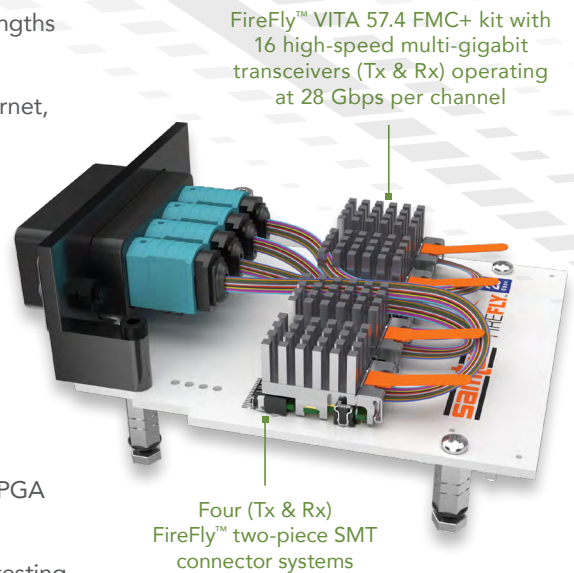

FireFly™ Test Kit

- The FireFly™ test kit allows designers real-time evaluation of an actively running copper or optical FireFly™ system in their own lab, using their own inputs
- Rated up to 25 Gbps
- Bulls Eye® test point system allows connection to test equipment
- Visit samtec.com/fik-firefly-xx for additional details

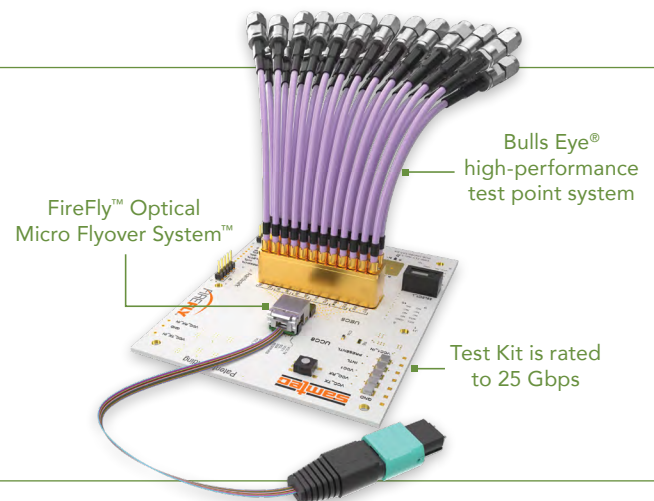

PCIe®-Over-Fiber Adaptor Card

- Features Samtec's PCIe®-Over-Fiber optical cable solution
- Supports Gen 3 platform; Gen 4 in development
- Delivers high data transfer rates with low latency, power management and guaranteed transmission
- Scalable configurations for cost optimized performance: x4 single, dual or quad, x8 single or dual, and x16 single
- Enables clear signal transmission with increased reach and cost optimization
- Contact firefly@samtec.com for details

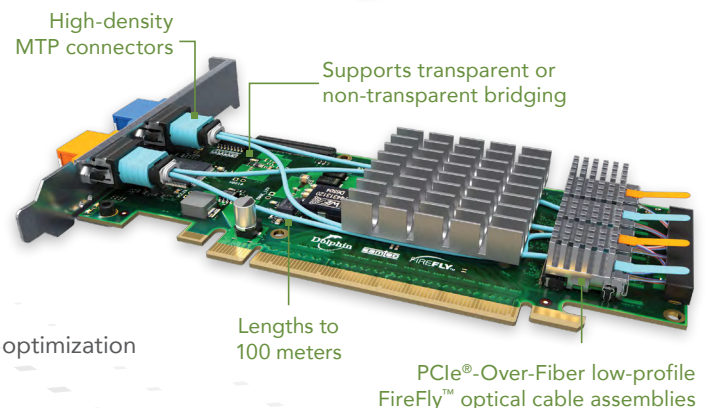

ADVANCED MICROELECTRONICS

Next-generation 56+ Gbps integrated circuits require robust signal integrity, optimized power integrity, compact packages and advanced assembly techniques. Samtec's team of technical experts, including packaging and assembly designers, Signal/ Power Integrity engineers, material scientists and system architects, collaborate to identify the ideal solution for any application. Contact sme@samtec.com to discuss your application.

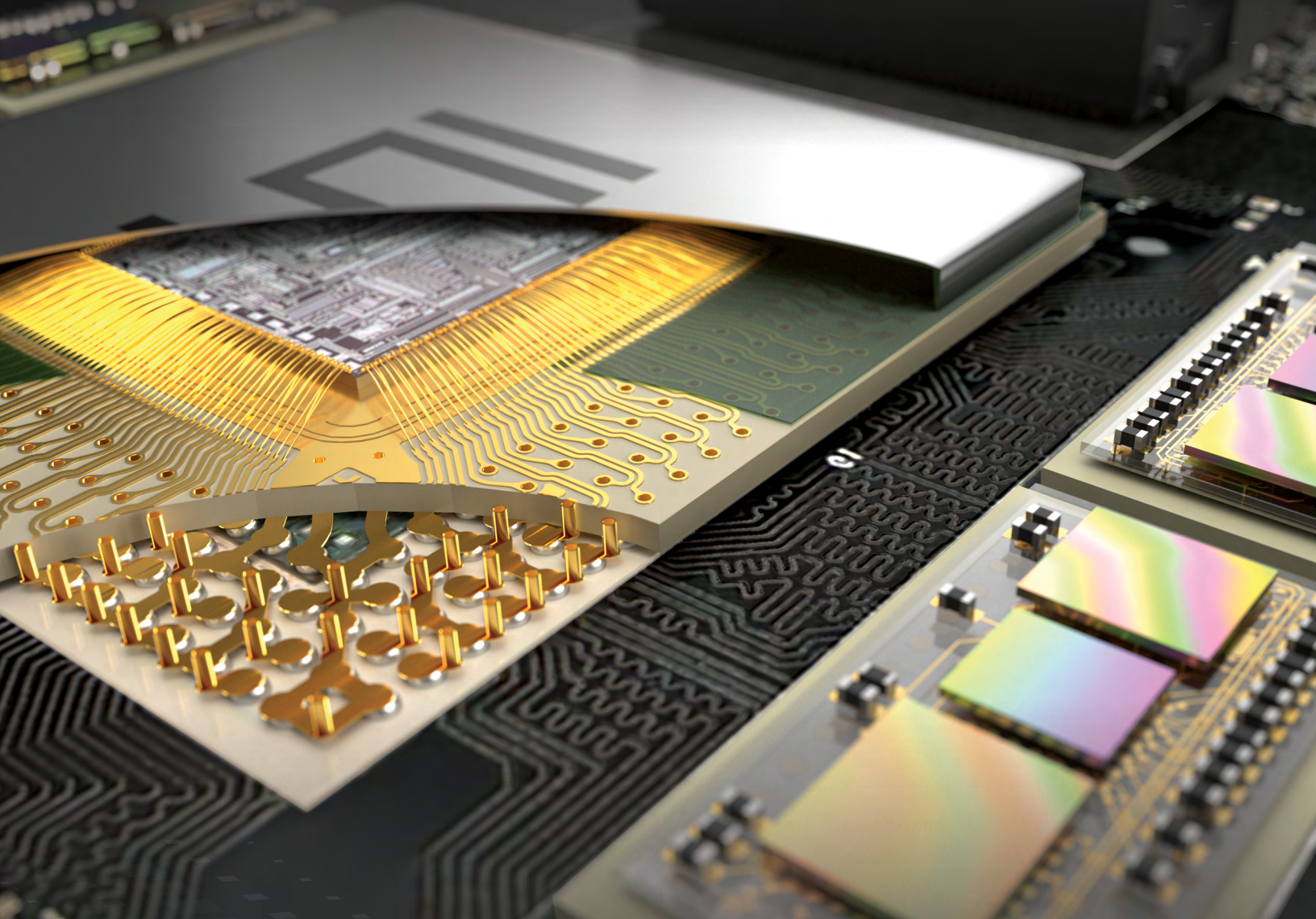

Glass Core Technology

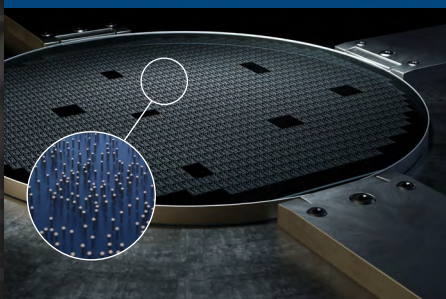

Advanced Packaging & Assembly

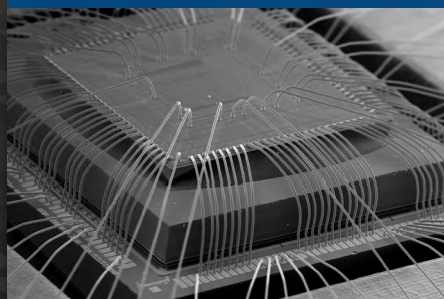

Next Gen 2.5D / 3D Packaging



THE FUTURE OF IC PACKAGING AT 56 Gbps & BEYOND

Integrated Stacking: 2.5D & 3D Packaging

As miniaturization and integration demands increase, the concept of stacking microchips is gaining more traction; stacked chips offer the benefits of electrical efficiency, less heat and power, and increased bandwidths. Samtec's proprietary Glass Core Technology enables solutions to aid in the development of these next generation packages.

- Because microchips require micro bumps, which are too small for direct attach to typical substrates or PCBs, 2.5D & 3D packaging is much more challenging
- Using glass as an interposer between the microchips and package substrate is an ideal solution, as it can be used to convert the top side micro bumps to fine pitch BGAs on the bottom side

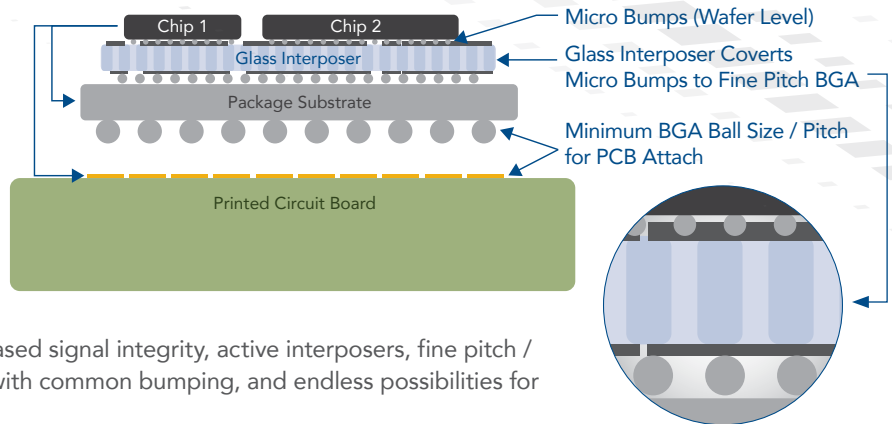

- Additional benefits of using glass include increased signal integrity, active interposers, fine pitch / high-count I/Os, and mixed chip technologies with common bumping, and endless possibilities for integrated stacking
- Other end product applications for glass include CMOS Imaging Sensors (CIS), high-performance RF packages, SiPho packages, high-speed multichip modules and system-in-packages
- Contact Samtec's technical experts at sme@samtec.com to discuss your design needs

MICROELECTRONICS EXPERTISE + GLASS CORE TECHNOLOGY

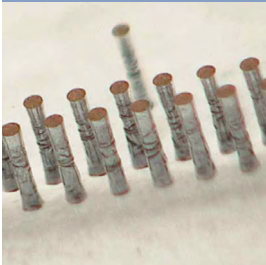
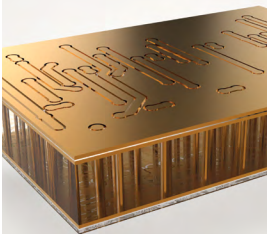
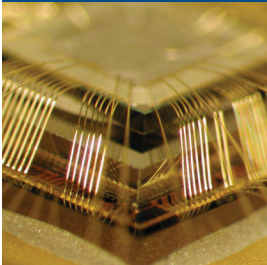
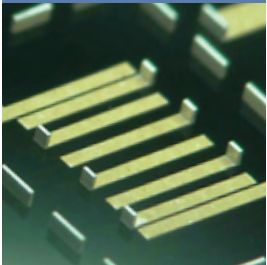
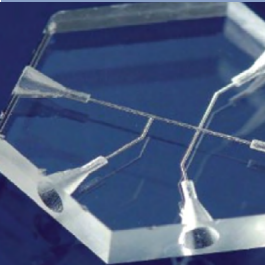
THROUGH-GLASS VIA (TGV)	REDISTRIBUTION LAYER (RDL)	ADVANCED IC PACKAGING	GLASS-BASED COMPONENTS	GLASS-BASED MICROFLUIDICS
Copper Metalization	Circuit Patterning	Design & Assembly	1-Layer Passives	Channels & Shapes
				
Borosilicate, Sapphire and Fused Silica	Borosilicate and Fused Silica	Traditional and Glass Substrates	Borosilicate and Fused Silica	Basic Surface Level Channel Geometry
Hermetic Sealing and Copper Via Fill	Basic Single-Layer Fan-Out Top and Bottom	Precision Die Attach	High-Reliability, High-Density, Precision Solutions	Basic Buried Channel Geometry
High-Reliability Copper Filled Vias Enable Miniaturization & Integration	Lower Cost Compared to Silicon-Based Interposers	Fine Pitch and Low Profile Wire Bond	Antennae, Inductors, Caps, Resistors and RF Filters	Biomedical Devices
		Flip Chip & Underfill		Lab-on-Chip
		Finishing		Sensors

PRECISION RF / TEST SYSTEMS

The high-density array designs and advanced cabling solutions within Samtec's Bulls Eye® product family enable optimized performance to 50 GHz (65 GHz systems in development). A compression interface, small footprint and high cycle count make Bulls Eye® ideal for high-performance test applications. Samtec also offers a full line of industry standard 50 Ω and 75 Ω RF connectors and cable assemblies, the industry's largest selection of 12G-SDI optimized RF interconnects, and a variety of original RF solutions for unique applications. For additional information, contact RFTechnicalGroup@samtec.com.

BULLSEYE® TEST POINT SYSTEM

Precision RF
Bulls Eye® Test Point Systems

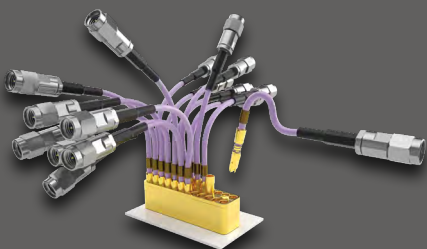

Industry Standard
50 Ω & 75 Ω / 12G-SDI

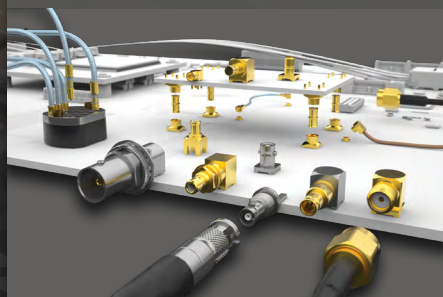

Original & Custom RF Solutions

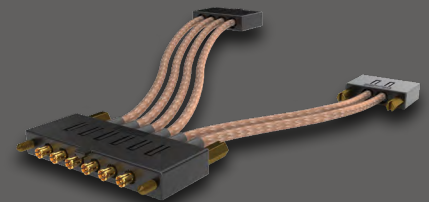

DEVELOPMENT PLATFORMS

Bulls Eye® 50 GHz Test Point Characterization Kit

- Enables testing and evaluation of Samtec's Bulls Eye® high-performance test point system
- Contains BE40A Series double-row, high-density array test point
- Routes high-speed differential pairs from BE40A Series to high-precision RF connectors
- Supports multiple high-precision RF connector options (e.g. 1.85 mm, 2.40 mm, 2.92 mm)
- Optimized SI performance via Samtec's Final Inch® BOR PCB trace routing
- Learn more at samtec.com/bullseye

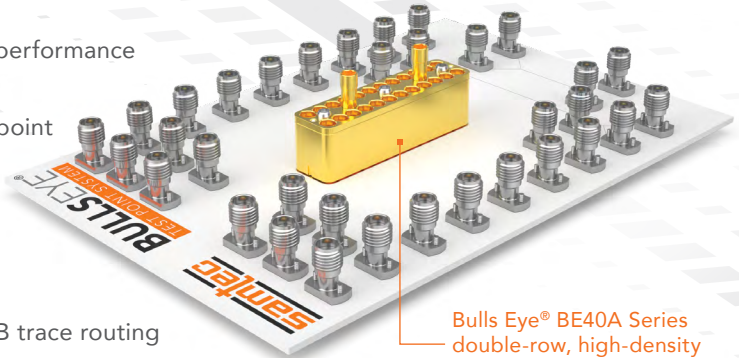

Bulls Eye® BE40A Series double-row, high-density array test point

Xilinx® Kintex® UltraScale™ FPGA KCU1250 Characterization Kit

- Enables evaluation of the 20 GTH 16.3 Gbps transceivers available on the UltraScale™ XCKU040-FFVA1156 FPGA
- Access to both the Integrated Bit Error Ratio Test (IBERT) demonstration and the Vivado® Design Suite enables quick evaluation of the industry leading GTH transceivers
- Ideal for connecting to a broad range of evaluation platforms, including backplanes and optical evaluation boards to high-speed test equipment
- Included are the Bulls Eye® test point system supporting a full GTH quad, with four transmit/receive pairs and five Bulls Eye® connector pads for the GTH transceivers and reference clocks
- Kit also includes two pairs of differential MRCC inputs with SMA connectors that expand I/O with three FMC interfaces
- Learn more at samtec.com/standards/fpgaku1250

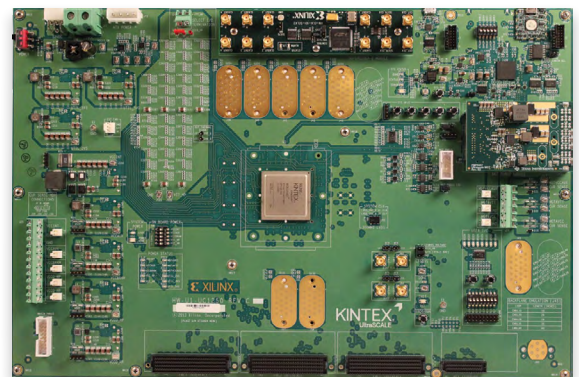

KCU1250 features Samtec's Bulls Eye® test point system and landing pads, and SEARAY™ VITA 57.1 FMC connectors

Fidus 12G-SDI HPC FPGA Mezzanine Card (FMC)

- The 12G-SDI HPC FMC from Fidus Systems and inrevium provides a video processing development platform for transportation of 4k/60fps video over a single coaxial cable link
- Contains 6x 75 Ω HD-BNC connectors which provide system I/O access:
 - 1x 12G-SDI input
 - 1x 12G-SDI output
 - 3x 12G-SDI In or Out
 - 1x Video Sync input
- System I/O can be doubled by adding a second, optional expansion module
- Includes 6x 75 Ω High-Density BNC Bulkhead Jack, Right-Angle and Through-Hole connectors (HDBNC-J-P-GN-RA-BH1)
- Learn more at samtec.com/12gsdi

75 Ω 12G-SDI optimized high-density BNC connectors

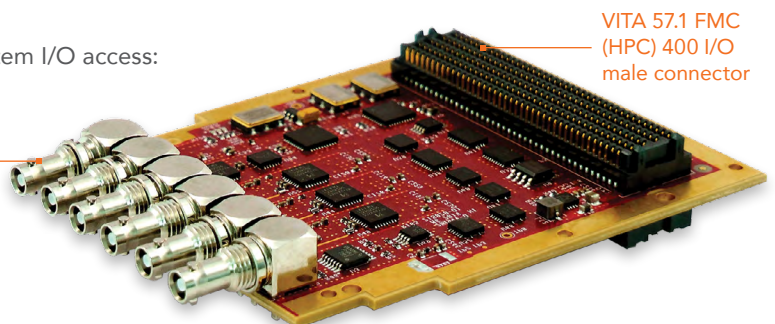

VITA 57.1 FMC (HPC) 400 I/O male connector

TECHNOLOGY CENTERS

Enabling Complete System Optimization from Silicon-to-Silicon™

By integrating specialized Technology Centers led by industry experts working side-by-side, Samtec fosters a unique environment conducive to true innovation and collaboration, along with the ability to provide the most complete level of service and support for interconnect system design, development and production in the industry.



INTEGRATION
LEADS TO **INNOVATION**

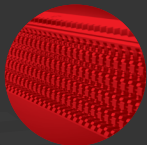

ADVANCED INTERCONNECT DESIGN

High precision stamping, plating, molding and automated assembly

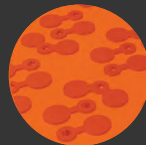

SIGNAL INTEGRITY GROUP AND SAMTEC TERASPEED CONSULTING

Full channel signal and power integrity analysis, testing and validation services

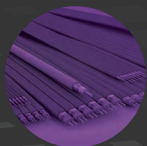

HIGH-SPEED CABLE GROUP

In-house R&D and manufacturing of precision extruded cable and assemblies



PRECISION RF GROUP

RF interconnect design and development expertise, with testing to 65 GHz



SAMTEC OPTICAL GROUP



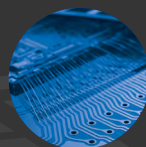



R&D, design, development and support of micro optical engines and assemblies



SAMTEC MICROELECTRONICS GROUP

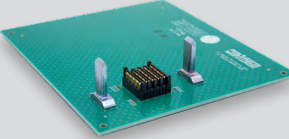

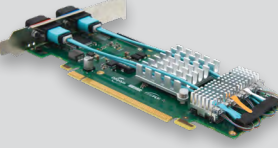
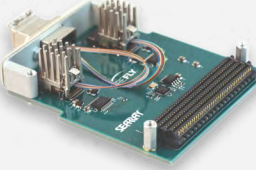
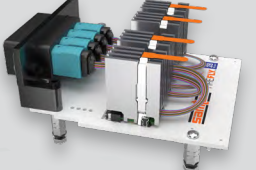
Advanced IC packaging design, support and manufacturing capabilities

DEVELOPMENT BOARDS & KITS

	Name	Kit Number	Description
	VITA 57.4 FMC+ HSPC Loopback Card	REF-197618-01	Samtec's VITA 57.4 FMC+ HSPC Loopback Card provides FPGA designers an easy-to-use loopback option for testing low-speed and high-speed multi-gigabit transceivers on any FPGA development board or FPGA carrier card.
	VITA 57.4 FMC+ HSPC / HSPCe Loopback Card	REF-197693-01	Samtec's VITA 57.4 FMC+ HSPC / HSPCe Loopback Card provides an easy-to-use loopback option for testing low and high-speed multi-gigabit transceivers on any FPGA development board or carrier card, and is an ideal substitute for 28 Gbps test equipment.
	ExaMAX® Loopback Card for Xilinx® Virtex® UltraScale™ VCU110 Development Kit	REF-200748-01	The VCU110 ExaMAX® Loopback Card routes 8 GTY MGTs from the Xilinx® Virtex® UltraScale™ FPGA through the ExaMAX® mated connector pair and back to the FPGA.
	FMC+ HSPC Loopback Card Supporting Xilinx® Virtex® UltraScale™+ VCU118 Development Kit	REF-194194-01	This loopback mezzanine card was based on an elongated version of the VITA 57.4 single width mezzanine card, designed for use with the Xilinx® UltraScale™+ VCU118 Development Board and is included in the VCU118 Development Kit available from Xilinx®.
	PCIe®-Over-Fiber Adaptor Card	PCOA-XX-XX-01	Samtec's PCIe®-Over-Fiber Adaptor Cards enable long distance PCIe® interfaces in computer-to-computer and computer-to-end point applications; the configurable PCIe® Gen 3 add-on card also supports transparent and non-transparent bridge links.
	14 Gbps FireFly™ FMC Development Kit	REF-193429-01	Samtec's 14 Gbps FireFly™ FMC Module is VITA 57.1 compliant and provides up to 140 Gbps full-duplex bandwidth over 10 channels from an FPGA to an industry-standard multi-mode fiber optic cable.
	28 Gbps FireFly™ FMC+ Development Kit	REF-200772-01	Samtec's 28 Gbps FireFly™ FMC+ Module is VITA 57.4 compliant and provides up to 448 Gbps full-duplex bandwidth over 16 channels from an FPGA to an industry-standard multi-mode fiber optic cable.
	FireFly™ Test Kit	FIK-FIREFLY-XX	Rated up to 25 Gbps, this kit allows the designer real-time evaluation of an actively running copper or optical FireFly™ system in their lab, with their inputs, via Samtec's Bulls Eye® system.

CHARACTERIZATION KITS

Samtec Signal Integrity Characterization Kits help simplify the design process and reduce time to market. Kits are available for many of our high-performance connector sets and standard high-speed cable assembly configurations. Custom kits are also available via our “mix-and-match” design approach (see facing page). Visit samtec.com/kits or contact kitsandboards@samtec.com.

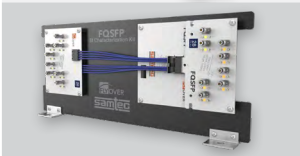
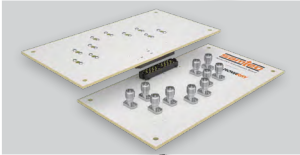
	Product Family	Series	Description
	ExaMAX® High-Speed Backplane Traditional Connectors	EBTF / EBTM	This SI test platform routes eight, high-precision differential pairs over a backplane using ExaMAX® connectors in a 4x10 configuration; it supports configurable backplane trace lengths via user-defined paddleboard placement.
	Flyover™ QSFP28 Double-Density	FQSFP-DD to ARC6	The Flyover™ QSFP28 Double-Density to AcceleRate® Cable SI Characterization Kit routes eight high-precision differential pairs via user-defined twinax cable lengths and RF connector options.
	Flyover™ QSFP28 Double-Density	FQSFP-DD to NVAX	The FQSFP-DD to NVAX SI Characterization Kit routes five high-precision differential pairs via user-defined twinax cable lengths and RF connector options to Samtec's NovaRay™ extreme density, high-performance array. An FQSFP-DD to DCH SI Characterization Kit is also available.
	Flyover™ QSFP28	FQSFP to DCH	The Flyover™ QSFP28 to Direct Attach Press-Fit Connector SI Characterization Kit routes eight high-precision differential pairs via user-defined twinax cable lengths and RF connector options.
	AcceleRate® Cable	ARF6 / ARC6	The AcceleRate® SI Characterization Kit routes eight high-precision differential pairs via user-defined twinax cable lengths and RF connector options.
	NovaRay™ Extreme Density Array	NVAM / NVAF	The NovaRay™ SI Characterization Kit routes multiple high-precision differential pairs in a 4 row, 2 bank mated connector pair with user-defined stack heights and RF connector options; it also supports testing of NovaRay™ cable assemblies (NVAM-C Series).
	High-Speed Micro Edge Card Connector	FCDP	The High-Speed Micro Edge Card SI Characterization Kit routes eight high-precision differential pairs from a FCDP-DV or FCDP-RA Series connector to user-defined RF connector options.
	LP Array™ Low-Profile Array	LPAM / LPAF	The LP Array™ SI Characterization Kit routes twenty high-precision differential pairs in an LPAM / LPAF Series mated connector pair with user-defined stack heights and RF connector options.
	Z-Ray® Low-Profile Interposers	ZRDP	The Z-Ray® SI Characterization Kit routes multiple high-precision differential pairs via user-defined ZRDP Series cable assembly lengths and ZCI Series interposers.

Additional SI Characterization Kits are currently in development.

Please contact Samtec's technical experts at KitsAndBoards@samtec.com for more information.

CUSTOM KITS FOR APPLICATION-SPECIFIC EVALUATION

Samtec's modular "mix-and-match" system for developing Signal Integrity Characterization Kits makes it easy to quickly obtain a customized, robust, high-quality kit for evaluating Samtec interconnect systems. A vast library of high-performance connector and cable options is available for designing a custom solution for your specific evaluation needs. Contact kitsandboards@samtec.com.

Twinax Flyover™ Systems End 1 / End 2 Options		Series
	Flyover™ QSFP28 Double-Density	FQSPF-DD
	Flyover™ QSFP28	FQSPF
	Direct Attach High-Speed Press-Fit Connector	DCH
	FireFly™ Copper Micro Flyover System™ (Mating connector set host board also in design)	ECUE

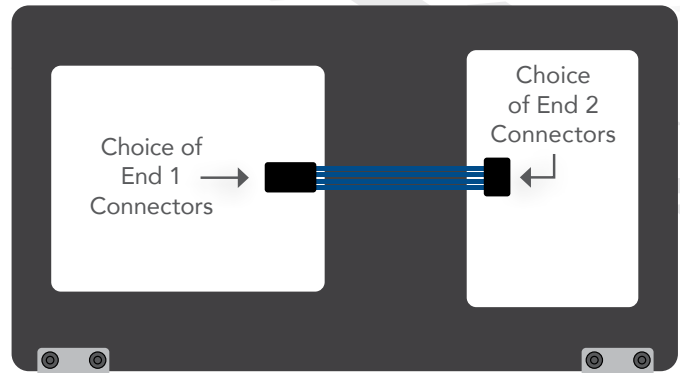

High-Speed Backplane End 1 / End 2 Options		Series
	ExaMAX® High-Speed Backplane Traditional Connectors	EBTF/ EBTM
	ExaMAX® High-Speed Backplane Cable	EBCF/ EBCM
	ExaMAX® High-Speed Backplane Direct Mate Orthogonal Connectors	EBDM/ EBCF-RA
	XCede® HD Small Form Factor Backplane Connector System	HDTF/ HDTM

* XCede® is a registered trademark of Amphenol Corporation.

High-Speed Mezzanine End 1 / End 2 Options		Series
	NovaRay™ Extreme Density Array (may also be used for Flyover™ cable assembly)	NVAM/ NVAF
	AcceleRate® Cable	ARF6/ ARC6
	AcceleRate® HD Ultra High-Density Strips	ADF6/ ADM6
	LP Array™ Low-Profile Array	LPAM/ LPAF
	High-Speed Micro Edge Card Connector & Cable Assembly	FEDP/ FCDP
	Z-Ray® Ultra Low-Profile Interposers	ZRDP



samtec
SUDDEN SERVICE®

UNITED STATES • NORTHERN CALIFORNIA • SOUTHERN CALIFORNIA • SOUTH AMERICA • UNITED KINGDOM
GERMANY • FRANCE • ITALY • NORDIC/BALTIC • BENELUX • ISRAEL • INDIA • AUSTRALIA / NEW ZEALAND
SINGAPORE • JAPAN • SHANGHAI • SHENZHEN • TAIWAN • HONG KONG • KOREA

MAY 2018

